

# System Comparison

## STANDARD REACTION FIXTURE

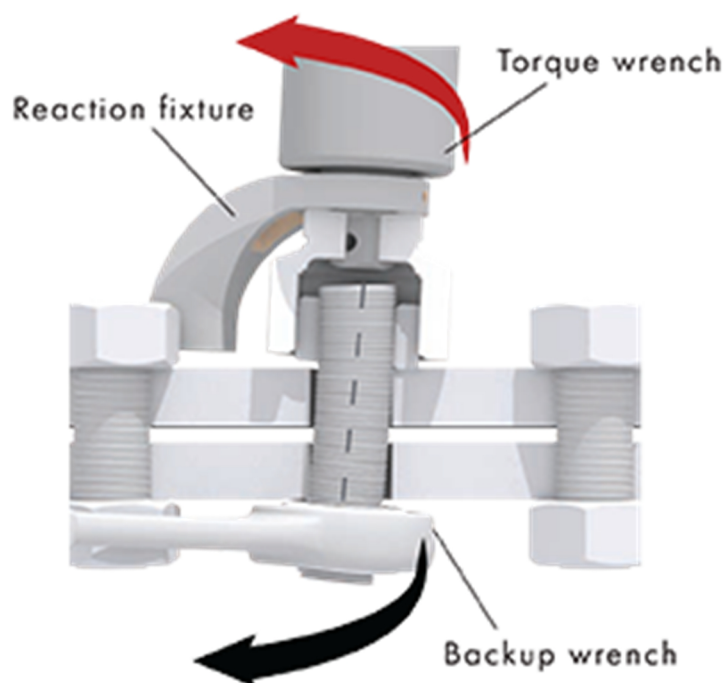

## HYTORC NUT

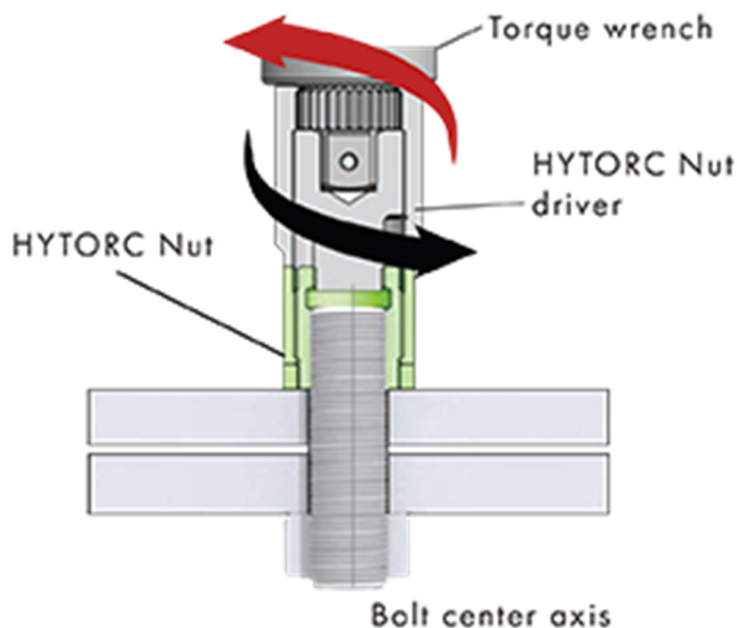

### SPEED

Job time is reduced through intuitive processes and the elimination of time consuming tasks like setting up reaction fixtures and removing backup wrenches by hammer.



Standard scatter

### ACCURACY

The coefficient of friction and thus the bolt load, depends on many factors. With the HYTORC Nut the scatter in bolt load is significantly reduced



Half of the scatter

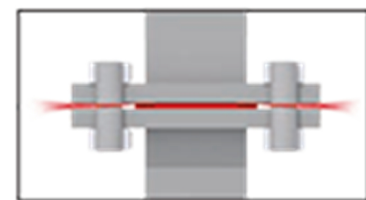

### INTEGRITY

Even and accurate bolt load applies even pressure to the flange, improving joint integrity and reducing the chance of leakage.

